

CURVED GLASS ISLAND CANOPY

900mm

ICG9BLS



- Island canopy
- Stainless steel and curved glass
- 1000m³/hr
- Ducted operation
- Re-circulating operation optional*
- LED touch control
- 3 speed fan
- 2 x Baffle filters for easy cleaning - dishwasher safe
- 4 x 3 watt LED lamps cooler and longer lasting

features

specifications

Airflow:	1000m ³ /hr	*Re-circulating Kit:	IA150IGRK
Noise level:	65 dBA on maximum setting	Carbon Filter:	CF120
Lighting:	4 x 3 watt LED lamps	Maximum Ceiling Height:	2.7 metres
Total wattage	540 Watts		
Power:	220 -240 volt / 50Hz (fitted with 10amp, 3 pin plug)		
Power Cord:	1.5 metre cable		
Ducting Spigot size:	150mm		

dimensions

Product Dimensions: 900mm (W) x 665-1170mm (H) x 600mm (D)

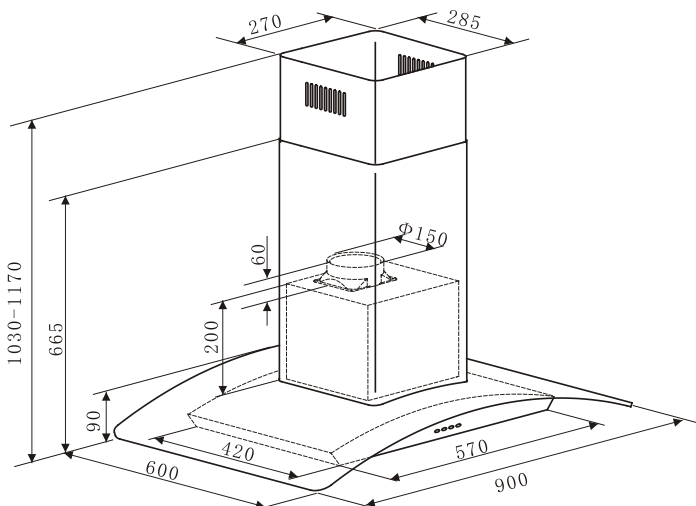

Warranty

2 years Parts and Labour

Customer Service

Our Nationwide Service Team can be contacted on our Toll Free Customer Service Number 1800 805 300 or by logging on to customercare@hapl.com.au



20 Carlotta Street
 Artarmon NSW 2064
 T: 02 9958 3111
 F: 02 9958 3555
 E: info@hapl.com.au
www.hapl.com.au